



V Max II Lead & V Max II Rear

Tri Axle Side Dump Lead & Tandem Side Dump Rear

Standard Specifications

- Overall Height - Lead 9' 10"/Rear 9' 5"
- Overall Length - Lead 35' 10"/Rear 28' 6"
- Axle Spread - Lead 60"/Rear 50"
- Wall Height - Lead & Rear 54"
- King Pin Setting - Lead & Rear 15"
- King Pin Height - Lead 50"/Rear 46"
- Body Capacity - Lead & Rear 20 Cubic Yards
- RTAC Compliant - Yes
- Box Front and Rear Wall - 1/8" AR450 Brinell
- Box Sides & Floor - 1/8" AR450 Brinell
- Top Rail - Formed Top Rail
- Aluminum 1/2 Round Fenders
- Suspension - INTRAAX AA250 Air Ride 25,000 LBS. Capacity Per Suspension
- Axles - 77 Inch Track
- Wheel- Unimount 10 Hole With Light Weight Hubs And Drums. 8.25 X 22.5
- Tires - Firestone T819 - 11R X 22.5
- ABS 2 Sensor System, 1 Module
- Steps at Rear of Trailer

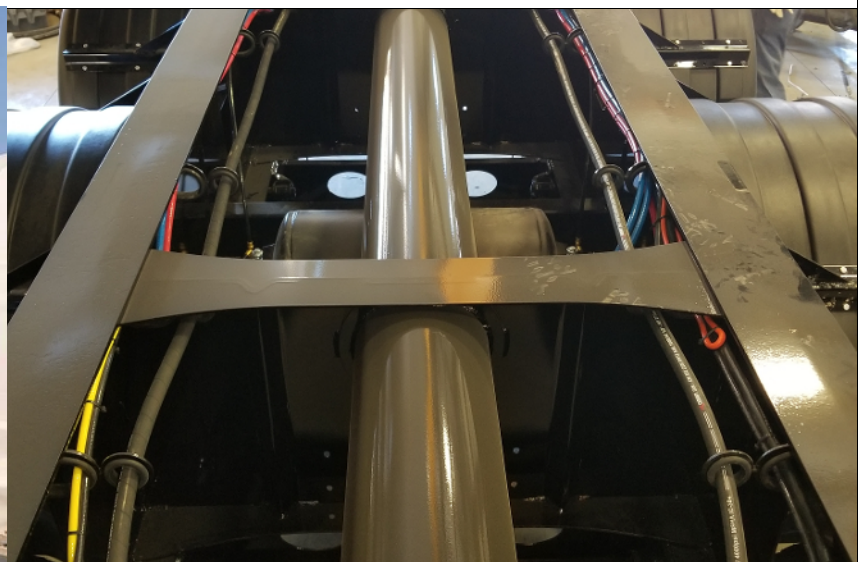

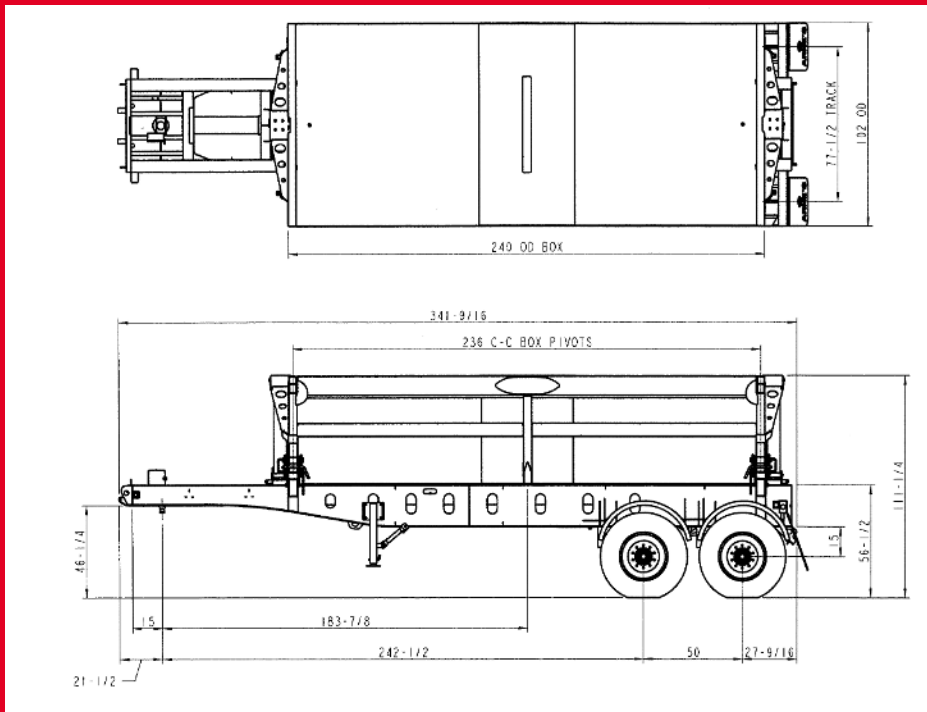
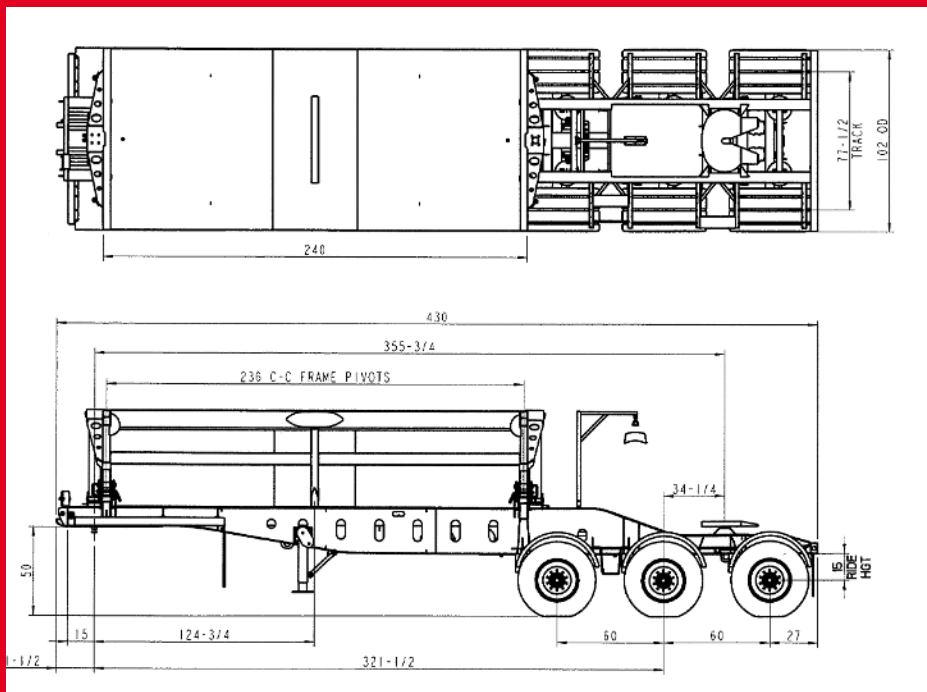

Available Options

- 22' Box Option
- 1 or 2 - Axle Auto Deploy Lift Kit
- Electric Side Kicker Tarp System - Mesh
- LED Light Package
- 11R24.5 - Tires
- Vibrator 12 Volt Electric
- Steel Aluminum Look-Alike Rims
- Disc Brakes
- Aluminum Machined or Polished Rims
- Mudflap Package - Frame Mounted, 2 In Front of Suspension
- Hubodometer - Drivers Side
- Two Speed Crank Down Legs
- Remote Grease System
- Black Poly Fenders
- Back up Alarm

Note: The information and specifications provided are based on our latest product information at time of publication. Arne's Trailers reserves the right to make changes at any time to products described or illustrated herein without notice or liability.