

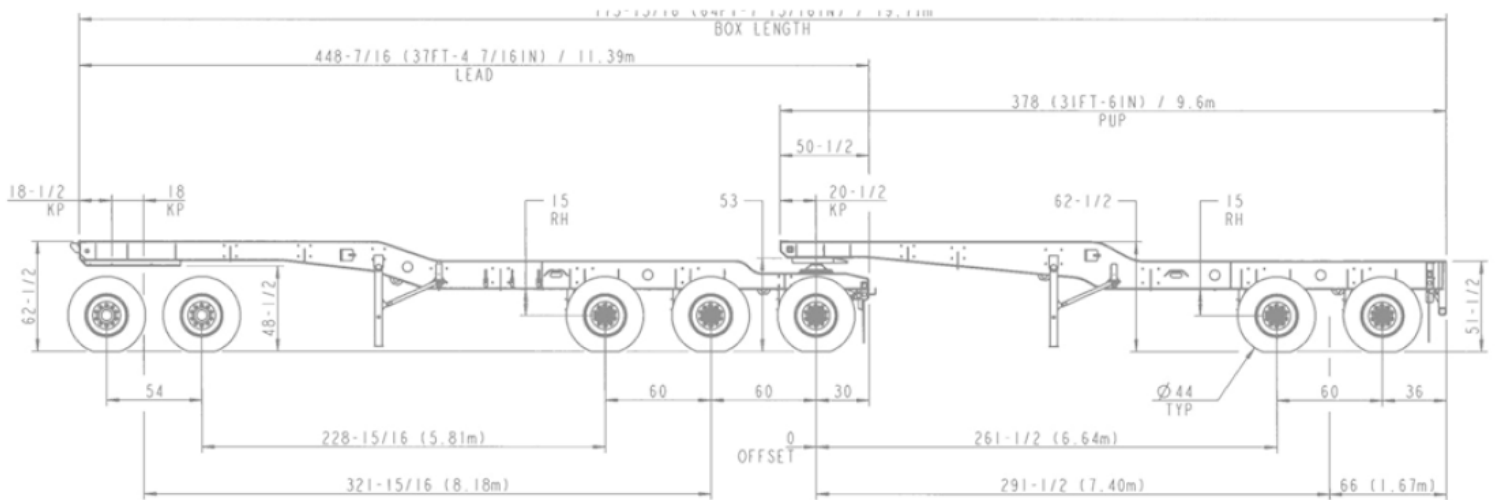

## Arne's Logger

- Available Models: Triaxle, Quad Axle, B Train, King B configurations
- Overall Length - Optional Configurations
- Axle Spread - 60"
- 2 King Pin Position: 2" Removable (18" & 36")
- King Pin Height: Optional Configurations
- Main Frame: Constructed of 100,000 psi tensile material
- Bunks/Stakes: Move-able (Bolt-on)
- Lighting: LED with light bar at rear, sealed harnesses
- Air Ride Suspension - 30,000 lbs. Capacity Per Suspension, 15" ride height with shutoff vales on each bag (Ridewell)
- Axles - 27,000 lbs. capacity per axle, prepped for tire inflation (drilled), parallel spindles
- Wheel- Unimount 10 Hole With Light Weight Hubs And Drums. 8.25 X 22.5
- Tires - Firestone T819 - 11R X 22.5
- ABS 2 Sensor System, 1 Module
- Landing Legs: Swing Up





MAIN B-TRAIN TRAILER LAYOUT

\*\*\* TRAILER HEIGHT +1.50" DUE TO TIRE LOAD RADIUS

ORIGINAL WORK ORDER # 30866 & 30867

AUG 08 2022

WELD PER ARNE'S WELDING STANDARD		ARNE'S	PAGE 1 OF 6
	TOLERANCES FRACTIONS 3/16" DECIMALS 0.03125" ANGLES 0.5°		
DESCRIPTION: SASKATCHEWAN SPECIFICATION			
ZZ04010 & ZZ04100 B-TRAIN LOGGER			
DRAWN BY:	DATE:	SCALE:	DRAWING NUMBER

# Available Options

Authorized Dealer

- Auto Deploy Lift Kit
- 11R24.5 - Tires
- Steel Aluminum Look-Alike Rims
- Aluminum Machined or Polished Rims

For More Information:  
Please Contact Your Authorized Dealer