









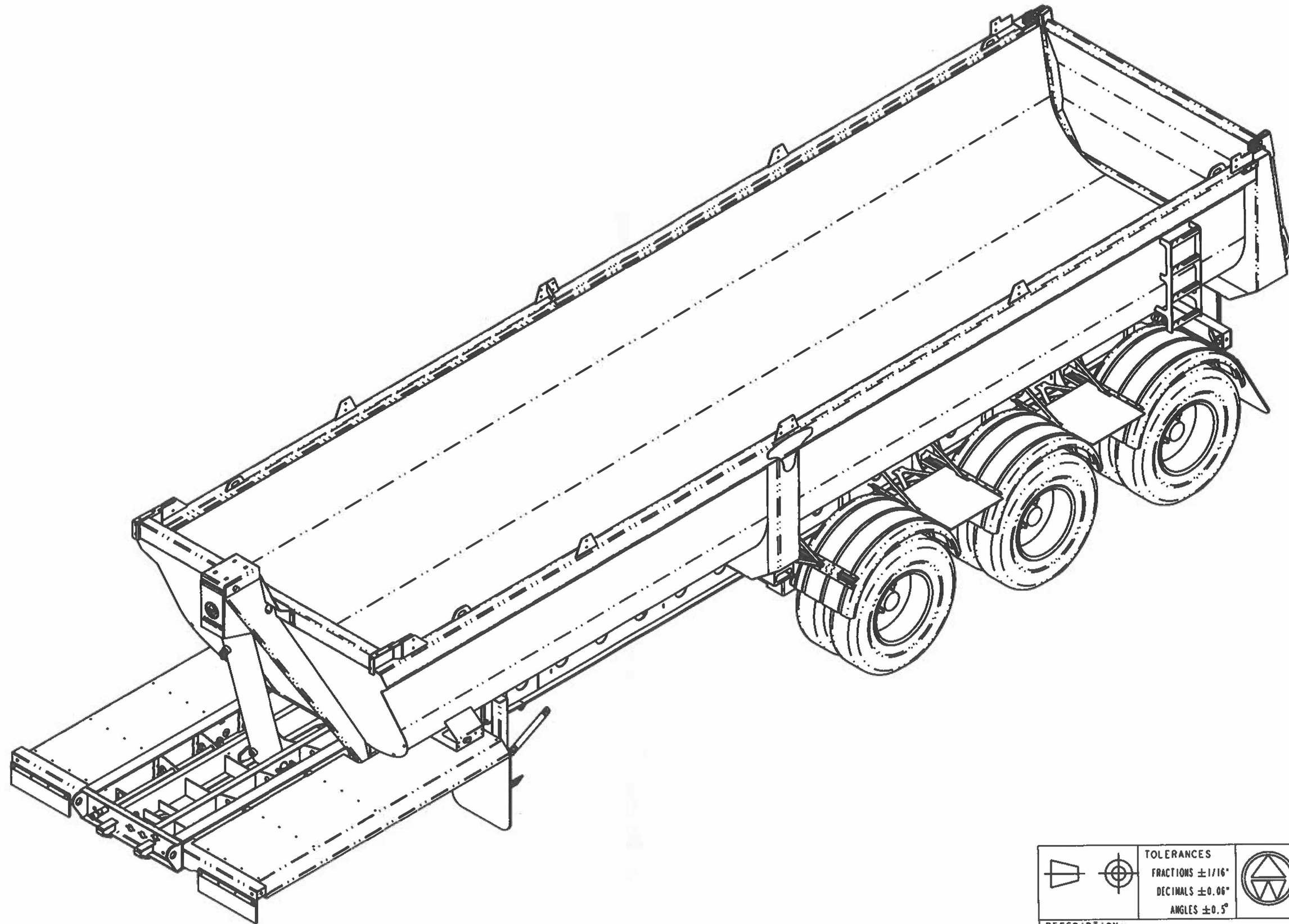

SUSPENSION: INTRAAX 250-15-775
 AXLE: 77 1/2" TRACK
 CYLINDER: 85-265

 		TOLERANCES FRACTIONS ± 1/16" DECIMALS ± 0.06" ANGLES ± 0.5°		ARNE'S
DESCRIPTION:				PAGE
TRIAxLE 360 TUB - ASPHALT				1
DRAWN BY: SB				OF
DATE: JUN30/22				10
SCALE: 1:32		DRAWING NUMBER		
EC040600		EC040600		

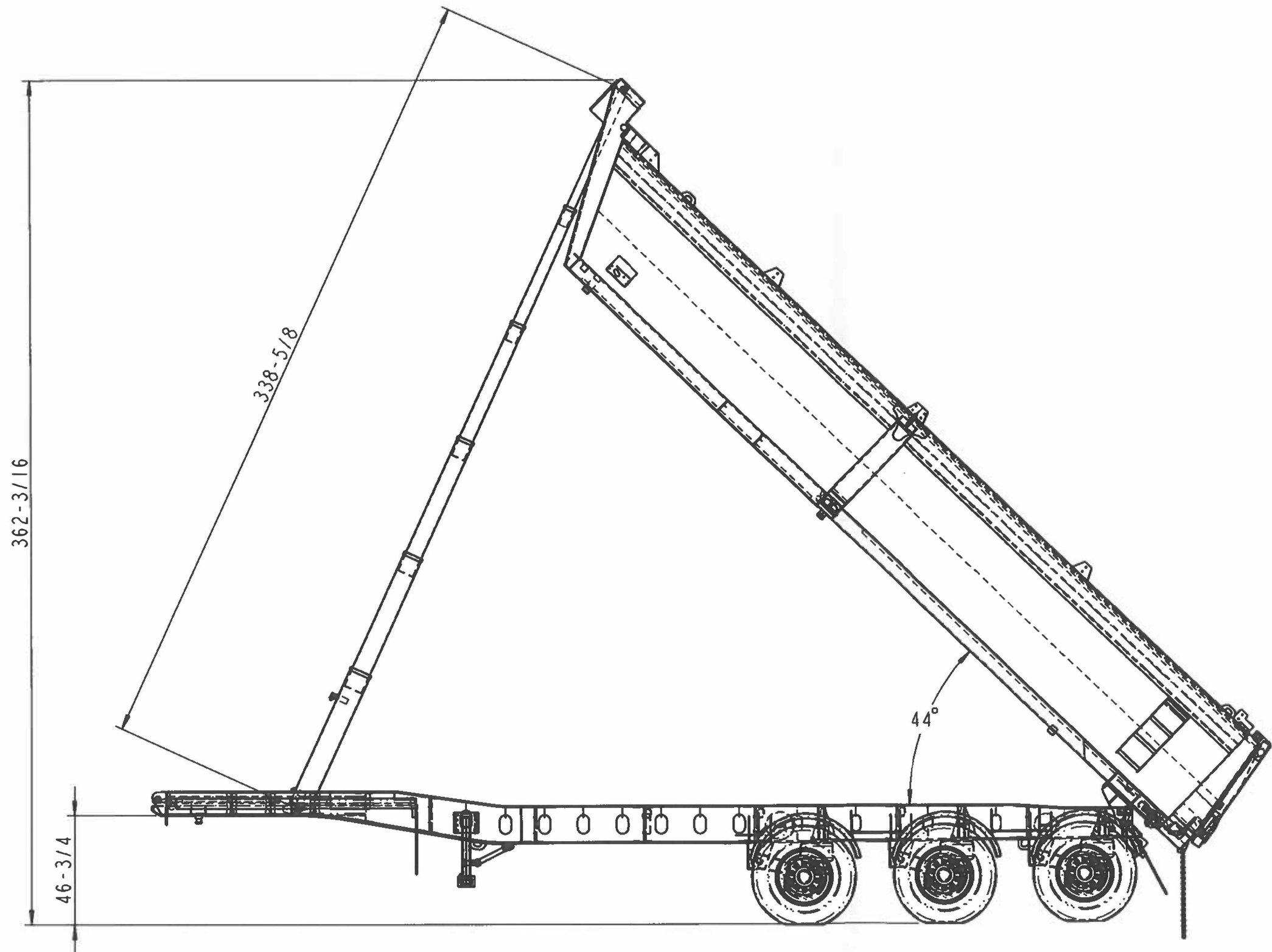



 		TOLERANCES FRACTIONS $\pm 1/16"$ DECIMALS $\pm 0.06"$ ANGLES $\pm 0.5^\circ$	 ARNE'S
DESCRIPTION: TRIAXLE 360 TUB - ASPHALT			PAGE 2 OF 10
DRAWN BY: SB	DATE: JUN30/22	SCALE: 1:32	DRAWING NUMBER EC040600

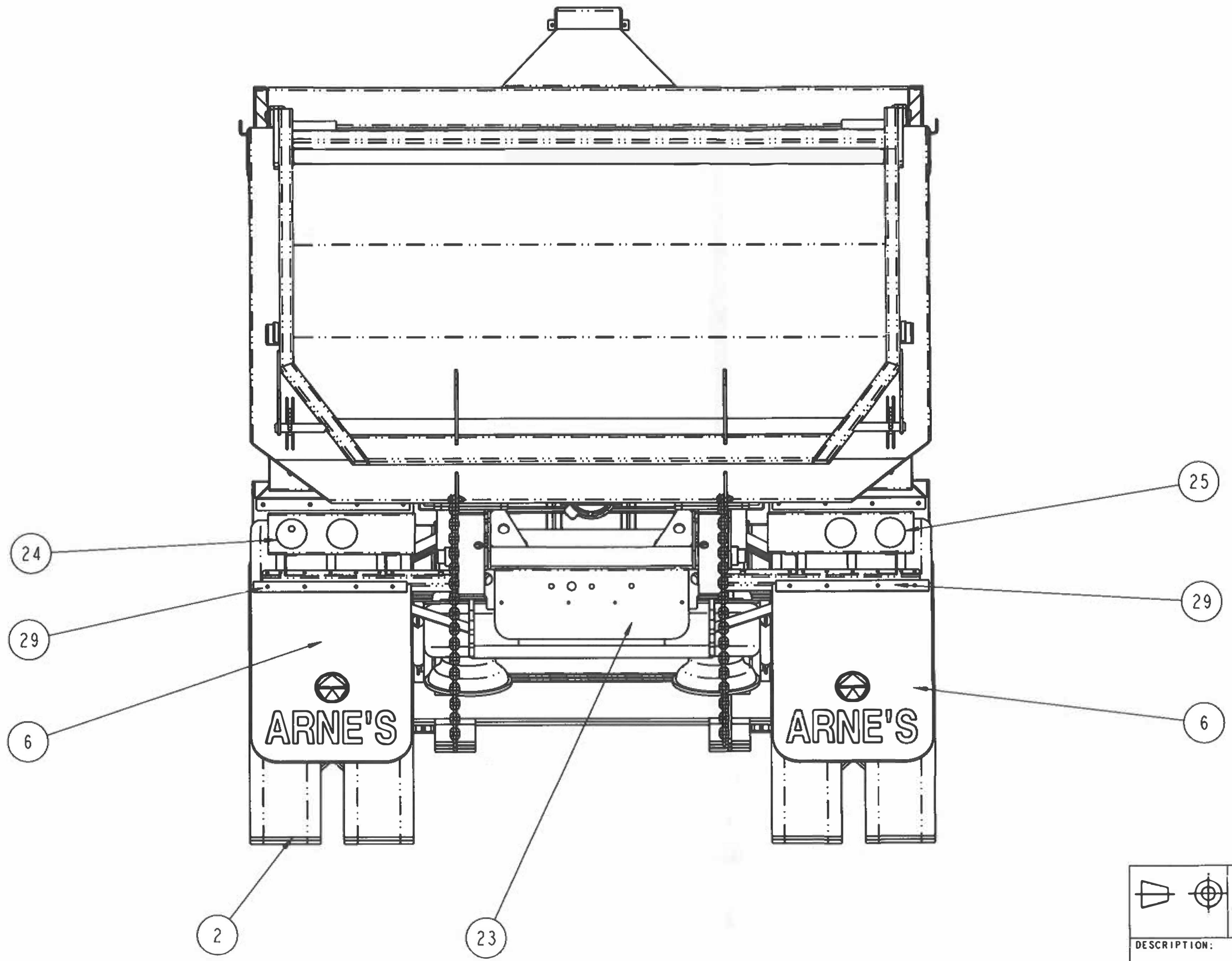

 	TOLERANCES FRACTIONS $\pm 1/16"$ DECIMALS $\pm 0.06"$ ANGLES $\pm 0.5^\circ$		ARNE'S		
					DESCRIPTION:
TRIAXLE 360 TUB - ASPHALT		DRAWN BY: SB	DATE: JUN30/22	SCALE: 1:160	DRAWING NUMBER EC040600



 	TOLERANCES FRACTIONS $\pm 1/16"$ DECIMALS $\pm 0.06"$ ANGLES $\pm 0.5^\circ$		ARNE'S	DESCRIPTION:	PAGE 4
				TRIAXLE 360 TUB - ASPHALT	OF 10
DRAWN BY: SB	DATE: JUN30/22	SCALE: 1:16	DRAWING NUMBER EC040600		