

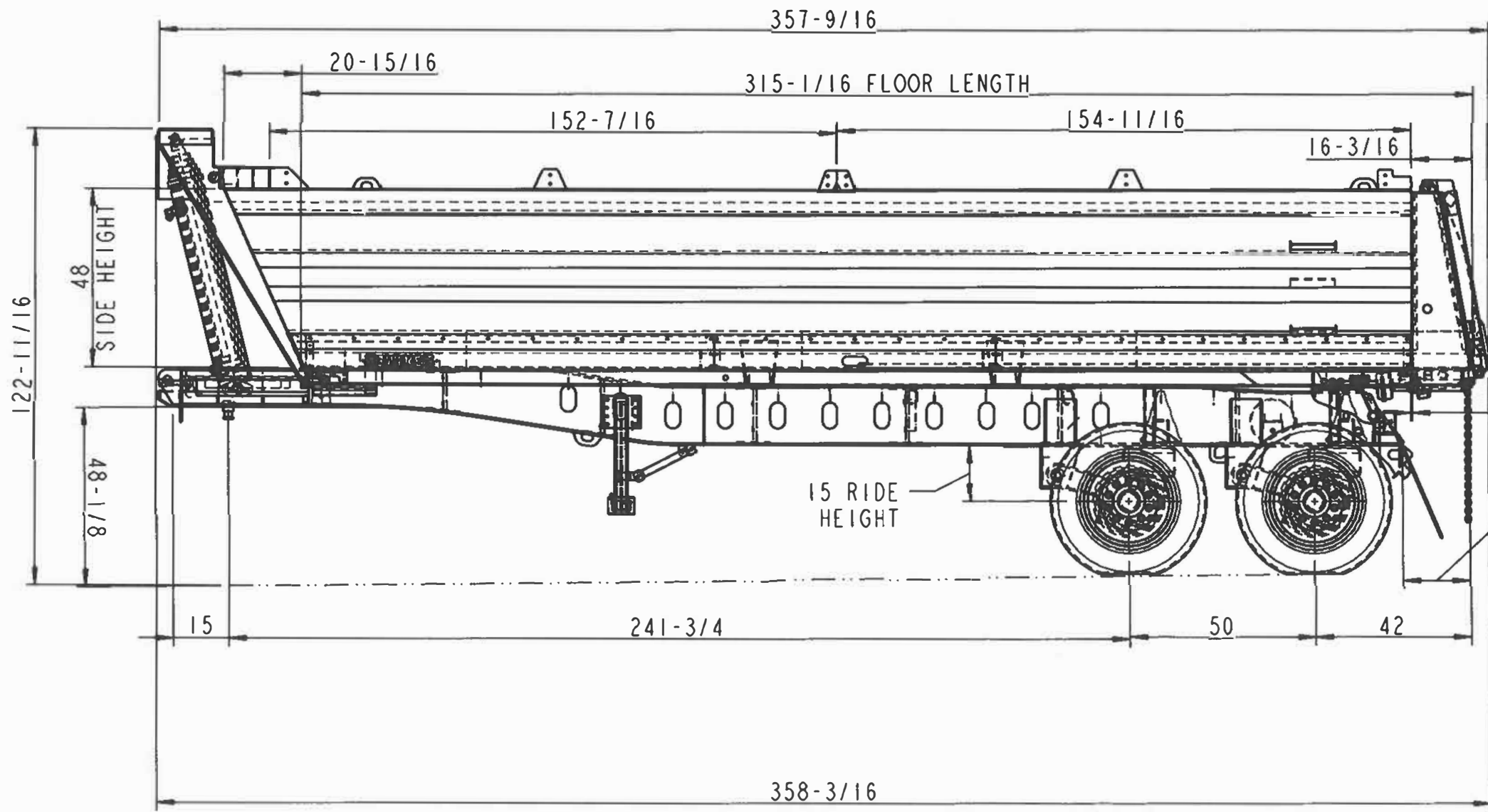



102



SUSPENSION: INTRAAX 250-15-775
 AXLE: 77 1/2" TRACK
 CYLINDER: 85-250

3/8 BOTH SIDES
 RUB RAILS

18
 OVERHANG

 	TOLERANCES FRACTIONS ±1/16" DECIMALS ±0.06" ANGLES ±0.5°		ARNE'S	
TDM 314 ASPHALT-FLAT FRONT (INTRAAX)				1
DRAWN BY: SB				OF
DATE: JUN30/22				9
SCALE: 19:700				DRAWING NUMBER
EC039900				

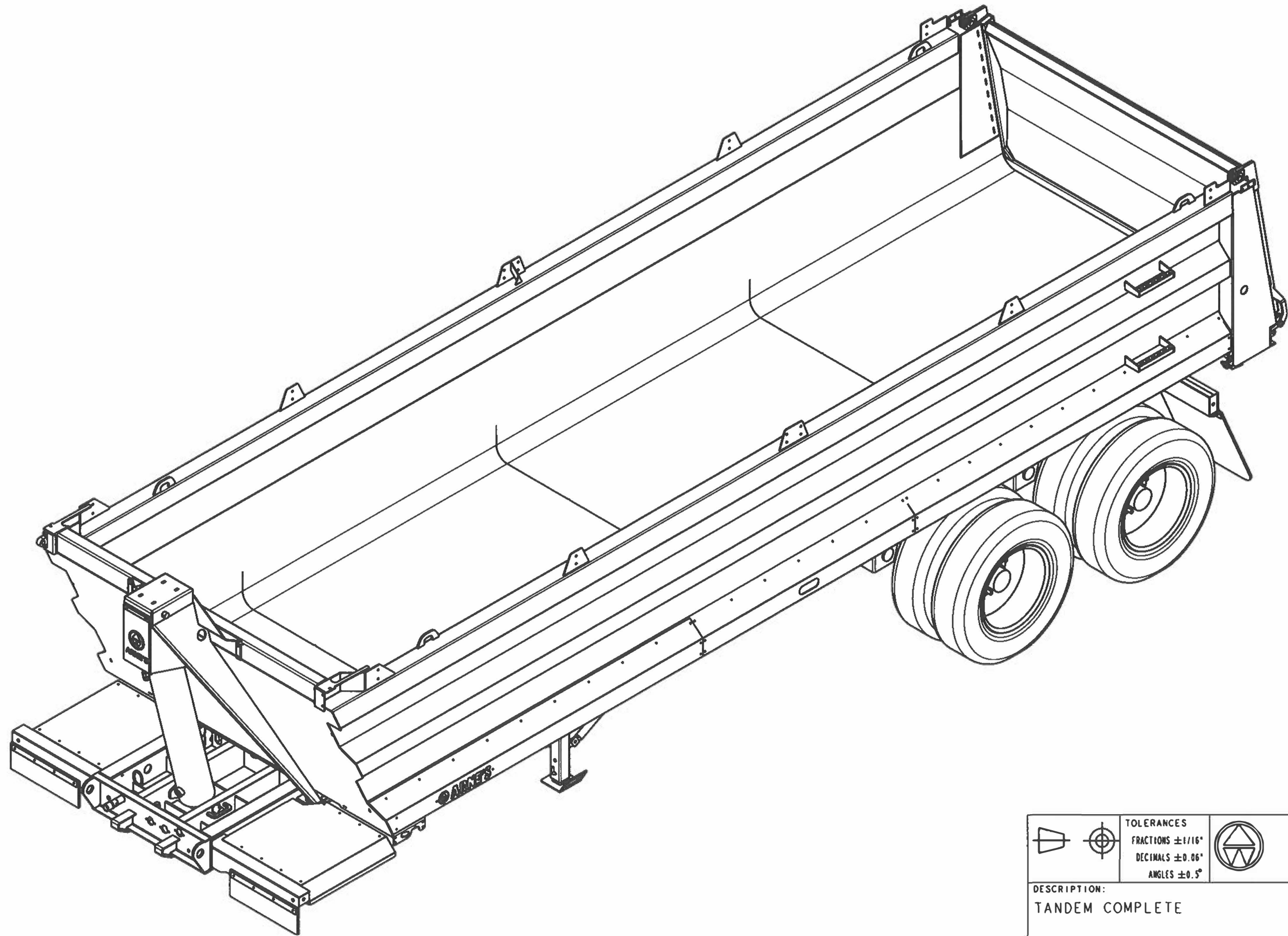

	TOLERANCES FRACTIONS $\pm 1/16"$ DECIMALS $\pm 0.06"$ ANGLES $\pm 0.5^\circ$			ARNE'S
	DESCRIPTION: TANDEM COMPLETE			
TDM 314 ASPHALT-FLAT FRONT (INTRAAX)				OF 9
DRAWN BY: SB	DATE: JUN30/22	SCALE: 1:25	DRAWING NUMBER EC039900	